

Corinthian House

17 Lansdowne Road Croydon CR0 2BX

COMING SOON

5th and 7th Floors

3,300 to 9,600 sq ft

with 14 parking spaces





M25 J7/M23 J8

Westfield Croydon

Boxpark

Ruskin Square

East Croydon Rail Station

Clapham Junction, Victoria, Waterloo
Gatwick, London Bridge, Beckenham Junction
Canary Wharf & Wimbledon

LOCATION

Corinthian House is a landmark office building in the heart of Croydon town centre, immediately opposite the newly opened entrance to East Croydon station, Britain's third busiest transport interchange, and at the head of the new pedestrian link to the proposed £1 billion Westfield and Hammerson retail development.

West Croydon station, with its East London line underground links, and the Tramlink light railway extending across South London to Wimbledon, are a few minutes walk as are the retail, food and leisure amenities of this vibrant town centre which is undergoing an unprecedented level of investment and development.



SPECIFICATION

- Refurbished Air-conditioned offices
- Locker Room and Showers
- Excellent Broadband and Connectivity
- Opposite East Croydon Station





The 5th and 7th floors are to be refurbished with each able to provide up to 4,800 sq ft and the ability to split into 2 suites from a minimum of 1,500 sq ft.

Each floor benefits from 7 parking spaces

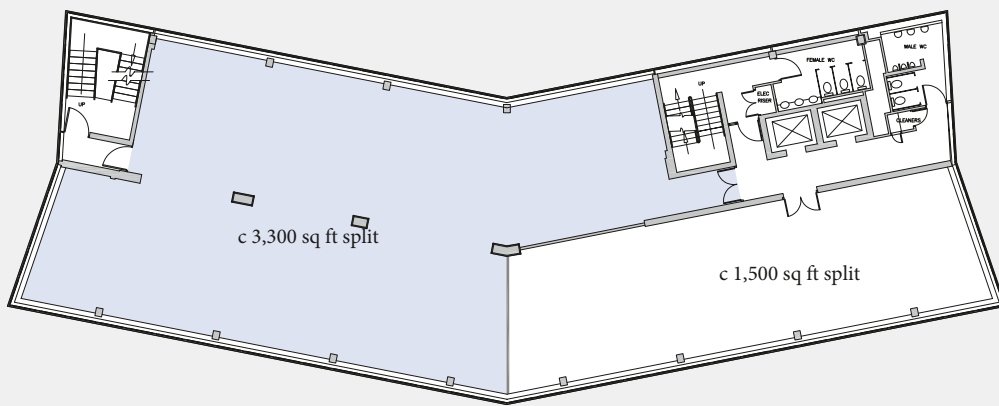

Floor & Size	Rent p.a.	Rates Payable (estimated) 2017/18	Service Charge Budget 2017/18
5th & 7th floors each c4,800 sq ft	£32.50 psf	£7.98 psf*	£8.28 psf

* Estimated post refurbishment

TERMS

New full repairing and insuring leases are offered direct from the freeholder.

EPC

To be confirmed post refurbishment.



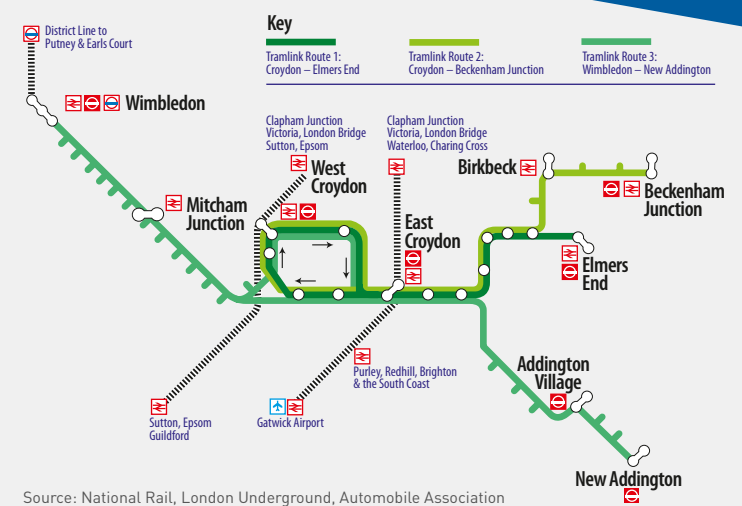

Source: National Rail, London Underground, Automobile Association

TRAVEL TIMES

FROM WEST CROYDON

Clapham Junction	Rail	21 mins
London Victoria	Rail	30 mins
London Bridge	Rail	40 mins
Norwood Junction	Rail/Tube	4 mins
Sydenham	Tube	12 mins
Canada Water	Tube	27 mins
Dalston Junction	Tube	46 mins
Sutton	Rail	12 mins
Epsom	Rail	28 mins

FROM EAST CROYDON

Clapham Junction	Rail	9 mins
Victoria	Rail	16 mins
Waterloo	Rail	28 mins
Gatwick	Rail	15 mins
London Bridge	Rail	13 mins
M25 J7 / M23 J8	Road	11 miles
Beckenham Junction	Tram	35 mins
Canary Wharf	Rail/Tube	35 mins
Wimbledon	Tram	26 mins



VIEWING

Please contact the joint sole agents.



Damian Lambourn
07796 953360
dl@lcprop.com



Neil Barker
nbarker@shw.co.uk
Holly Purvis
hpurvis@shw.co.uk

Owned & managed by



Important notice. These particulars do not constitute an offer or contract and although they are believed to be correct their accuracy cannot be guaranteed and they are expressly excluded from any contract. Dec 2017